

Characteristics



SRC05-ST



SRC08-ST



Type		SRC05-ST	SRC08-ST
Nominal load	Current	A	16
	Voltage	V	300
Dielectric strength	Between coil and contact	V/min	4000
	Between contacts	V/min	2500
Max. tightening torque	Nm	-	
Wire size	AWG/mm ²	20-14/0.5-2.5	
Ambient temperature	°C	-40~+85	
Unit weight	g	37	42

Accessories

Socket	ID tag	Bus Jumper	Module
SRC05-ST			
SRC08-ST	SR2P	ST01CC	AMD

Clip selection table

Relay H (mm)	15	20	25
Clip Type			
	SR15L	SR20F	SR25C

Dimensions (mm)

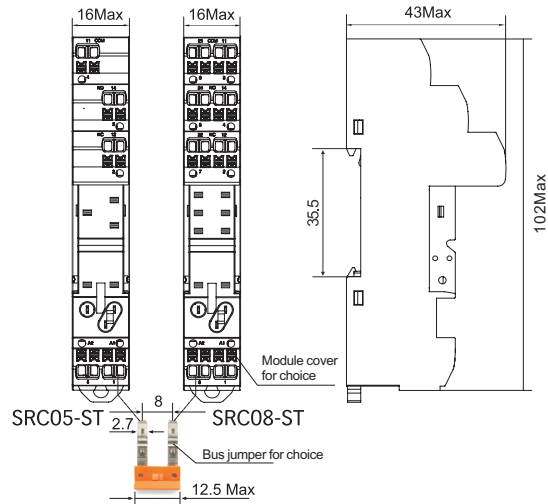

Connection Diagrams

